

3 DECK DRAWER COUNTER CHILLER

- Blower System
- Self Closing Drawer



3DR1200

3 DRAWER

MODEL

Temperature°C (celsius)	+1 to +4
External Dimension (mm)	1200 x 760 x 900
Internal Dimension (mm)	718 x 597 x 610
External Finishing	SS/G1
Internal Finishing	SS
Voltage/ Frequency (V/ Hz)	230V/1/50Hz 220V/1/60Hz
Weight (kgs)	119
Compressor	1/6Hp
Wattage (W)	361 - 399
Ampere (A)	2.4 - 2.6
Energy Consumption (kw/ 24h)	2.9 - 3.2
Condenser	Air Cooled
Refrigerant/ Grams	R134a / 330g
Defrost System	Forced Air Circulation
Temperature Control	Digital
Number of Drawer	3
Size of Drawer (Foodpan)	6 x FP 1/1 - 2 1/2
Maximum Depth of Foodpans (mm)	65

3DR1200

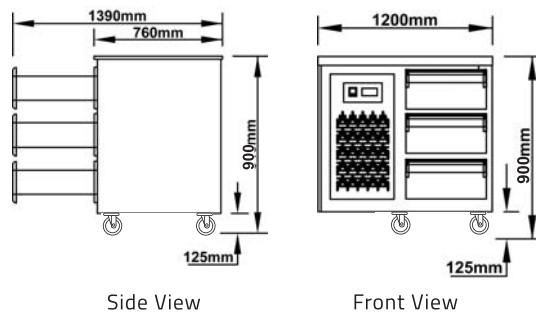

*Note:-
Option : CW - Castor Wheel / BF - Bullet Feet

As product improvement is an on going process, we reserve the right to change specifications or design without notice.